

The Canadian Association of Liquor Jurisdictions

**Product Identification Standards for Use in the
Distribution of Beverage Alcohol**

September, 1998r

Table of Contents

INTRODUCTION	1
INTERNET VIEWING	1
GETTING STARTED	2
<i>If You are Already Marking Your Products with U.P.C. or EAN</i>	2
<i>If You Need a Company (Manufacturer) Number</i>	2
<i>If You Need Information to Plan Your U.P.C. Program</i>	3
<i>If You Need Additional Technical Information</i>	3
STANDARDS FOR CONSUMER PACKAGES	4
ACCEPTED NUMBER FORMATS	4
STANDARDS FOR SCANNABILITY	4
CHANGE OF U.P.C.....	4
<i>Change of Company (Manufacturer) Number</i>	5
<i>Item Number</i>	5
REUSE OF NUMBERS	5
PRODUCT MARKING STANDARDS.....	6
<i>Individual Bottles</i>	6
<i>50 ml. Bottles</i>	6
<i>Individual Cans</i>	7
<i>Cans in a Hi-Cone Pack Multi-pack</i>	7
<i>Open Carrier Packs</i>	7
<i>Bottles or Cans in Closed Cartons or Boxes</i>	7
<i>Bottles in Permanent Outer Packages</i>	8
<i>Bottles in Temporary Outer Packages</i>	8
<i>Free Item Packs</i>	8
<i>Vintages</i>	9
<i>Non-beverage Products</i>	9
COMBINED CSPC AND U.P.C. MARKING	10
STANDARDS FOR SHIPPING CONTAINERS	12
HUMAN READABLE INFORMATION (CLOSED SHIPPING CONTAINERS ONLY).....	13
DESCRIPTION OF PRODUCT ON SHIPPING CONTAINER	14
STRUCTURE OF THE U.P.C. SHIPPING CONTAINER CODE (SCC-14).....	16
<i>Packaging Indicator "0"</i>	16
BAR CODE FORMAT	17
<i>Interleaved 2 of 5 Symbol</i>	17
<i>UCC/EAN-128 Symbol</i>	19
<i>Use of U.P.C. or EAN Symbol on Shipping Containers</i>	20
POSITION OF THE BAR CODE SYMBOL	20
<i>Symbol located on the end (shortest panel) of the case</i>	20
<i>Symbol located on the side (longest panel) of the case</i>	20
<i>Symbols on labels</i>	21
<i>Reduced height symbols</i>	21
<i>Bar code symbol location on corked products</i>	22
LOCATION OF HUMAN READABLE BAR CODE NUMBER	22
WHEN THE SHIPPING CONTAINER IS ALSO THE RETAIL SELLING UNIT.....	23
TRAY PACKED PRODUCTS.....	23
STANDARDS FOR PALLETS	23
SERIAL SHIPPING CONTAINER CODE (SSCC-18)	24
<i>Pallet Label Format</i>	25
<i>Pallet Label Location</i>	25

APPENDICES.....	26
APPENDIX A: U.P.C. CONCEPTS	26
<i>U.P.C.-A</i>	26
<i>U.P.C.-E</i>	26
<i>EAN Numbers</i>	27
<i>Assignment of U.P.C. Numbers</i>	28
<i>Symbol Quality</i>	28
<i>Symbol Size</i>	29
<i>Reducing the Size of the Symbol</i>	30
Truncation	30
<i>Symbol Colours</i>	31
<i>Orientation of the Symbol</i>	31
Symbol Curvature.....	31
APPENDIX B: RELATIONSHIP TO EXISTING U.P.C. AND CSPC STANDARDS	32
APPENDIX C: CALCULATION OF CHECK DIGITS	33
APPENDIX D: QUALITY SPECIFICATIONS FOR SYMBOLS	34
APPENDIX E: GLOSSARY OF TERMS	36
APPENDIX F: SUMMARY OF VERSION CHANGES	38
May 10, 1996.....	38
September 1998.....	39
APPENDIX G: BAR CODE SYMBOL DIMENSIONS.....	40
U.P.C.-A	40
U.P.C.-E	41
EAN-13.....	42
EAN-8.....	42
SCC-14 using Interleaved 2 of 5 bar code	43
SCC-14 using UCC/EAN-128 bar code.....	44
SSCC-18	45

Introduction

The purpose of this document is to describe standards for the use of the Universal Product Code (U.P.C.) or EAN bar codes, in the distribution of beverage alcohol in Canada.

In general, the standards comply with internationally accepted U.P.C./EAN standards. There are minor variations that are noted in "Appendix B".

The standards have been prepared under the auspices of the Canadian Association of Liquor Jurisdictions (CALJ) by the Product Identification Standards Committee (PISC). The committee is made up of representatives of liquor jurisdictions and the supplier community.

The standards call for:

- the use of the U.P.C. or EAN on all consumer units (effective June, 1997);

- the use of the Shipping Container Code (SCC-14), EAN code or U.P.C. on all shipping containers (effective January, 1997);

- the use of a Serial Shipping Container Code (SSCC-18) label on all pallet loads (effective date to be determined by each provincial jurisdiction but no earlier than June 1, 1999).

A product description on the shipping container is mandatory as of January 1, 1999. It must be located on the same end as the bar code.

The existing CSPC number will continue to be used during a transitional period. A target date of January 1, 2002 has been set for the elimination of CSPC number but this date is subject to review.

A note about the bar symbols used in this document

The bar codes used in this document are for illustration purposes only. Changes in size or magnification can occur during printing and reproduction. The illustrations should not be used to determine actual dimensions. A table of dimensions is provided as Appendix G

Internet Viewing

The latest version of this manual may be viewed on-line in English and in French via the Internet at <http://www.lcbo.com> in the section U.P.C. standards.

Getting Started

Readers who are not familiar with the basic structure and format of the U.P.C. or EAN may wish to read "Appendix A" first.

If You are Already Marking Your Products with U.P.C. or EAN

If you are using U.P.C. or EAN today and are conforming to published U.P.C./EAN guidelines then your product will generally conform to the standards in this document.

There are minor differences between these standards and the generally used U.P.C./EAN standards. These differences are set out in "Appendix B" of this document.

There are also specific requirements for shipping containers (cases and trays) and pallet labels.

If You Need a Company (Manufacturer) Number

Canadian-based companies should contact:

The Electronic Commerce Council of Canada
835 Don Mills Road
Suite 301
Don Mills, Ontario M3C 1V9

Phone: (416) 510-8039
or 1-800-567-7084
Fax: (416) 510-8043
<http://www.eccc.org>

Suppliers in United States of America should contact:

The Uniform Code Council Inc.
863 Old Yankee Road, Suite J
Dayton, OH 45458

Phone: (937) 435-3870
Fax: (937) 435-7317
<http://www.uc-council.org>

Suppliers in other countries should contact their local issuing body associated with EAN International for a Company Number or:

EAN International
Rue Royale 145, B-1000
Brussels Belgium

Phone: +32 2 227 10 20
Fax: +32 2 227 10 21
email: info@ean.be
<http://www.aliis.be/ean>

If You Need Information to Plan Your U.P.C. Program

1. Read this manual carefully.
2. Obtain the manuals listed below. The U.P.C. Implementation Guide has a number of useful planning checklists.
3. Consult with packaging designers and suppliers of packaging materials. Typically, they have already had significant experience with U.P.C. requirements.

If You Need Additional Technical Information

This document provides specific information about the marking of retail selling units, shipping containers and pallets.

Readers who require more detailed technical information may wish to obtain one or more of the following manuals. The manuals published by the Uniform Code Council (UCC) and the Electronic Commerce Council of Canada (ECCC) are identical. Each is available at a nominal fee from the ECCC or UCC. French versions of the manuals are also available from the ECCC.

U.P.C. Implementation Guide: How to Develop and Maintain a Top Quality U.P.C.	An excellent introduction to establishing a U.P.C. program with a number of useful checklists.
Quality Specification For The U.P.C. Printed Symbol	A comprehensive guide to measuring the quality of symbols on consumer products. Provides information needed to set up effective quality controls for U.P.C. symbols.
Application Standards for Shipping Container codes	A comprehensive guide to standards for shipping container marking. Includes useful technical information for producing shipping container and pallet bar codes.
Barcoding for Designers, Printers & Packagers	Emphasizes the issues related to package design and the printing of packaging materials.

Standards for Consumer Packages

Accepted Number Formats

CALJ members will accept consumer packages with the eight or twelve digit formats (Versions E and A respectively) of the North American U.P.C. or the eight or thirteen digit formats of the international EAN.

The term U.P.C. when used in this document is meant to include all versions of the U.P.C. or EAN symbols.

Standards for Scannability

All symbols on Consumer Products must meet the standards for quality of the Electronic Commerce Council of Canada, The Uniform Code Council (USA) or EAN International.

Symbol quality should be measured with an approved verifier using the test procedures defined by the ECCC and UCC. The minimum acceptable test scores are listed in "Appendix D".

The members of CALJ recognize that some package formats are unable to comply with the exact requirements of these standards. Individual members will therefore accept products that do not strictly comply with the standards if they pass the following test.

Based on a sample of one hundred units and using a presentation scanner, ninety-five percent of the units must scan on the first pass and all units must scan in two passes.

This exception is intended primarily for packages where the physical design of the product or its label limits the space available for the symbol. It is not to be used as an excuse to reduce the symbol size for aesthetic reasons. When allocating space on a label, government regulatory requirements have priority, followed by the bar code symbol. Both have priority over marketing information.

Change of U.P.C.

Changes in the U.P.C. number can result from a change in either the Company Number or the Item Number.

When the U.P.C. number changes the supplier must provide sufficient advance notice to its customers to ensure an orderly transition to the new number.

Change of Company (Manufacturer) Number

If an existing brand is acquired or sold, the new manufacturer should phase in its own Company Number on the product. This is not strictly necessary if the brand will operate as a separate company.

In practice, this phase-in can take many months and sometimes years.

It is, therefore, recognized that a single supplier may have products with more than one Company Number, or that the same Company Number may legitimately be in use by more than one supplier.

If the U.P.C. number changes the number on the shipping container must also change at the same time.

Item Number

Changes in price, package graphics or package format (e.g. glass bottle to plastic bottle) do not require a change in U.P.C. number.

A change in package format may affect recycling charges and advance notice of the change should be provided to the jurisdictions affected.

The U.P.C. number and the CSPC must be changed if:

the volume of product in the package changes (e.g. 700 ml. to 750 ml.);

or, the number of units in the consumer unit changes (e.g. six pack to eight pack);

or, if a change in alcohol strength results in a tax or duty rate change under Customs and Excise regulations.

Suppliers may change a U.P.C. number for other reasons without changing the CSPC but, as this may disrupt the flow of goods to the consumer, U.P.C. changes should only be made when absolutely necessary.

The U.P.C. number must change if the CSPC number is changed.

A change in the number of consumer units in a shipping container does not require a change in the consumer unit U.P.C. number. (See the Section "Standards For Shipping Containers" for further details.)

Reuse of Numbers

A U.P.C. number must not be reused by a supplier within four years of its last shipment unless it is for the reintroduction of the same item.

Product Marking Standards

Individual Bottles

There are five approved ways to locate a symbol on a bottle. They are:

- on the front label;
- on a wrap around front label so that the symbol, while part of the front label, is on the side when the product is displayed;
- on a back label;
- on a sticker;
- for certain types of bottles, on the tamper evident seal.

For all retail selling units the symbol should be placed as close to the bottom of the package as possible.

The symbol must not be applied to the actual bottom of a bottle.

If the symbol is located on the tamper evident seal, it will be better to orient the symbol in ladder style (bars parallel to the bottom of the package) to avoid the distortion that can occur by wrapping the symbol around the neck (see Orientation of the Symbol in "Appendix A").

Applying the symbol to a neck ring is no longer supported by ECCC and UCC standards because of poor scanning performance. CALJ members will accept marking on a neck label if this is the only location available to the supplier and the symbol passes the scanning test described in the section "Standards for Scannability" above. Suppliers who intend to mark a neck ring must recognize that they are taking a risk. Care must be taken in designing and applying the label to avoid problems such as wrinkling or the obscuring of the symbol by incorrect overlapping of the ends of the ring. The symbol should also be oriented in ladder style.

50 ml. Bottles

A symbol is required.

The symbol should be oriented in ladder format.

Because of its small size, it may be necessary to truncate the bar height to accommodate the symbol.

Reduction to the minimum magnification (80%) should be considered, particularly, if truncation is necessary.

Suppliers may wish to use an eight digit Version E or EAN-8 symbol, if possible, on these packages.

Individual Cans

Cans may be sold individually even if they are also retailed in a closed multi-can container. All cans must have a U.P.C. symbol.

The symbol must be located near the bottom of the can away from any welds, beads or flutes that could distort the symbol.

Depending on the size of the symbol and the diameter of the can, it may be necessary to orient the symbol with the bars parallel to the bottom of the can (ladder style) rather than perpendicular to the bottom (picket fence).

If the cans are also sold in a closed container then this container must also have a U.P.C. symbol but it must have a number that is different from the number on the individual can.

Cans in a Hi-Cone Pack Multi-pack

When a package consists of cans that are connected by plastic rings, the U.P.C. on the can will be used. A separate U.P.C. designating the pack is not required.

For point of sale purposes, retailers may define the item as either the can or the pack and use an override key or a multiple key for the exceptions.

Open Carrier Packs

Bottles in open carrier packs must be U.P.C. marked.

A U.P.C. is not required on the carrier.

If a U.P.C. is printed on the carrier pack (required by U.P.C. standards, and possibly by some jurisdictions outside Canada, but not by the Canadian Association of Liquor Jurisdictions) the number on the carrier must be different from the number on the individual bottle.

For point of sale purposes, retailers may define the item as either the can or the pack and use an override key or a multiple key for the exceptions.

Bottles or Cans in Closed Cartons or Boxes

A closed carton or box sold as a retail unit must have a U.P.C. symbol on the bottom or side to comply with U.P.C. standards. Cases or boxes that are not shipping containers only require one U.P.C. symbol.

If the retail selling unit is also the shipping container then the U.P.C. must appear on two locations on the shipping container. The supplier has the option of marking either the top and bottom or two adjacent sides. The use of the two symbols is necessary to comply with the requirements for shipping containers and to facilitate scanning at the point of sale. Scanners at the point of sale will generally be positioned to scan the side or top of the retail package but not the bottom. This second symbol is

recommended but is not mandatory if the shipping container contains six or fewer bottles or cans of 450 ml. or less.¹

Bottles that are not tamper-evident are not intended for individual sale and do not require a U.P.C. on the bottle. Only the outer retail package must be marked.

Tamper evident bottles and all cans must have a U.P.C. symbol on the bottle or can even when sold in a sealed case.

The U.P.C. number on the outer package must be different from the U.P.C. number on the can or bottle.

Bottles in Permanent Outer Packages

Brands that are normally sold as a bottle in a box or other outer package must have a U.P.C. on the outer package. The supplier, at its option, may put a U.P.C. on the bottle. In this case, the bottle should have the same number as the outer package.

The U.P.C. should be located on the bottom of the outer package. If the construction of the package does not allow the symbol to be placed on the bottom, it should be located on the side near the bottom.

When boxed and unboxed bottles of the same product are shipped in the same shipping container for individual sale, the same U.P.C. may be used on all units.

When two or more bottles are combined in a box to create one selling unit, a new U.P.C. must be assigned. Care must be taken to ensure that only the U.P.C. on the outer package is visible to the scanner.

Bottles in Temporary Outer Packages

When a product is placed in a temporary outer package and there is no price difference, the outer package must carry the same U.P.C. number as the product inside. Care must be taken to ensure that only one symbol is visible to the scanner.

Free Item Packs

When a free item is attached to a product, the same U.P.C. should be used. (U.P.C. rules call for a separate U.P.C. but this is not required by the Canadian Association of Liquor Jurisdictions).

If the free item also contains beverage alcohol, for example if the free item is a 50 ml. bottle, the same U.P.C. can only be used if:

1. there is no change in the alcohol strength of the original product;
2. and the cost to the jurisdiction including duty and taxes is the same as the regular product.

¹ The compliance deadline for this requirement is February 1, 1999.

The free item should not have a U.P.C. symbol. If it does, it should be defaced or obscured so that it cannot be scanned at the checkout.

Vintages

Different vintages (crop years) of the same wine may carry the same U.P.C. if it is a general list product.

If there is an intention to market and track the different vintages individually, or if two or more vintages will be retailed at the same time but at different prices, a separate U.P.C. must be used.

Products that are not general list will require a different U.P.C. for each vintage year.

As some products may not be considered general list in all jurisdictions, it may be necessary to offer the same vintage with two different U.P.C. numbers (i.e. one U.P.C. for the jurisdictions who wish to track the vintage year and a different U.P.C. for jurisdictions who consider the product to be general list). The decision is at the discretion of the supplier, based on the requirements of individual jurisdictions. Suppliers should review the U.P.C. numbers with the jurisdictions at the time the product is listed.

Non-beverage Products

Non-beverage products must have individual U.P.C. symbols that conform to the standards for general merchandise and apparel.

Combined CSPC and U.P.C. Marking

When all jurisdictions have converted to the U.P.C., the requirements for CSPC marking will be phased out. The CSPC number will be required until at least January 1, 2002.

Suppliers must continue to observe the current CSPC requirements until that time.

As a transitional step, suppliers may wish to combine the CSPC and U.P.C. symbols, in the same area of the label. This is an option for the supplier. There is no requirement to change the CSPC markings. Suppliers wishing to do so must observe the following guidelines.

1. The CSPC number must be placed above or on either side of the U.P.C. symbol and on the same background as the U.P.C. The preferred method is to place the CSPC above the U.P.C.

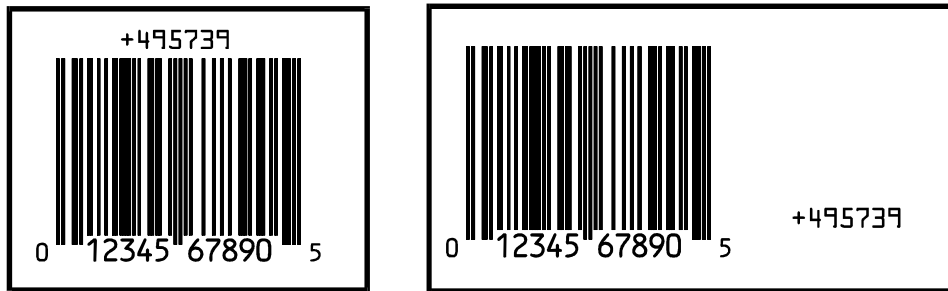

2. If the CSPC is placed to the side of symbol, it may be parallel to the symbol's bars.

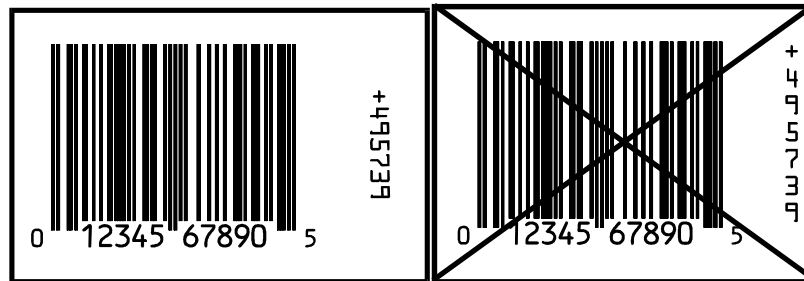

3. If placed beside the U.P.C. the CSPC must be placed outside the quiet zone of the U.P.C. symbol.²

² The quiet zone is the clear space at each end of the symbol. It is used by the scanner to establish the background reflectance level when scanning. It is nine times the width of the narrowest bar in the symbol. If the human readable characters have been placed according to specification, the outer edge of the first and last characters will be approximately aligned with edge of the quiet zone.

4. When placed above the U.P.C., the CSPC must be oriented in the same direction so that both can be read at the same time.

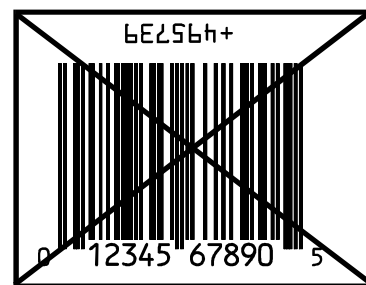

5. If placed above the U.P.C., the space between the CSPC characters and the top of the U.P.C. bars must be at least 01.3 mm (0.05"). There must be at least 2.5 mm. (0.10 inches) of clear space above the CSPC characters.
6. The CSPC number must not be placed above the U.P.C. symbol if doing so would require truncation of the bars.



7. The CSPC characters must be at least 2.5 mm (0.1") high and must be printed at ten characters to the inch. The plus sign must be maintained. Any sans serif font of equal weight and equal or better legibility may be used in place of the OCR-A font.

Standards for Shipping Containers

Each shipping container that is not a retail selling unit, will be marked with a combination of human readable and bar coded information.

A bar coded Shipping Container Code (SCC-14 also known as EAN-14, Distribution Unit Number, DUN-14 or Trade Unit Number, TUN-14) symbol must appear on one side and one end. The U.P.C. should be used on the shipping container only if the case is a retail selling unit.

As a transitional measure, a U.P.C. Version A or an EAN-13 symbol may be used on a container that is not a retail selling unit. This is intended to allow suppliers more time to implement the SCC-14/EAN-14. Acceptance of the U.P.C. or EAN on shipping containers that are not retail selling units may be withdrawn in the future. When a U.P.C.-A or EAN-13 is used it must be magnified to between 160% and 200% of the nominal symbol size. The number on the shipping container must be different than the number on the retail units it contains.

Specifications for the size and location of the human readable information are given in the chart on pages 13 and 14.

There are special rules for the human readable information on shipping containers that are also retail selling units and for products packed in trays. They are described on page 23.

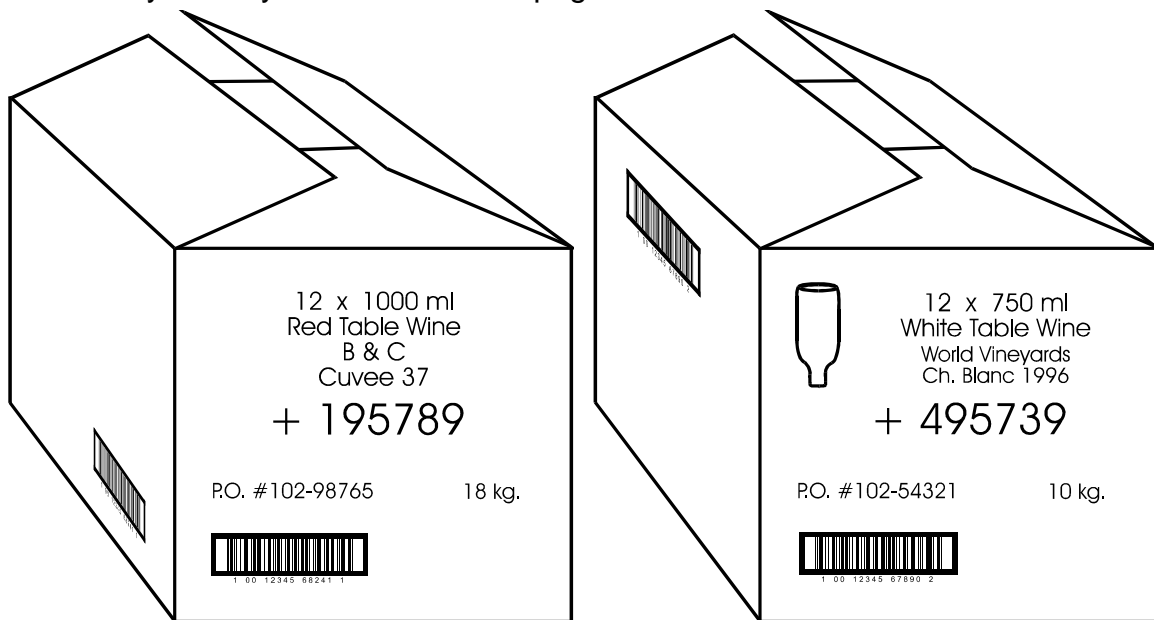

Use of the bottle symbol

The bottle symbol must only be used when the bottle has a cork closure and the supplier recommends that it be stored in the "corks down" position. It should indicate the orientation of the bottles in the case. Screw cap bottles should not have a bottle symbol.

The preferred orientation of the bar code on the side of the case is with the eye readable characters easily readable in the recommended storage position. As this may not be possible for some labeling equipment, inverted symbols will be accepted.

Human Readable Information (closed shipping containers only)

Shipping Container Marking	Location	Minimum Height	Other Specifications
CSPC Number	both ends or on the same side and end as the bar codes	25 mm. (1.0")	+ function must be included
Shipping Container Code Number	with SCC bar code	5.0 mm. (0.20")	Exact placement and format is dictated by bar code symbology used See page 22
Production Date, or Best Before Date, or Lot Number or Purchase Order Number	same side or same end as bar code	13 mm (0.5")	Any one of the four may be used. Approved date formats for production date are: <ol style="list-style-type: none"> 1. month, day, year (e.g. Jan. 21 2001) 2. dd/mm/yy in numeric or alpha-numeric format (e.g. 21/01/01 or 21/A/01) 3. yy/mm/dd or yyyy/mm/dd in numeric or alpha-numeric format (e.g. 2001/01/21 or 01/A/21) Note: the letter I is omitted from the alpha-numeric format. <ol style="list-style-type: none"> 4. y/jjj where "jjj" is the Julian day of the year "y". For years after 1999, a four digit format should be used e.g. 2001 rather than a two digit format if there is a possibility of confusing the year with the month or day. The date code must be clearly identifiable if part of a larger bottling code.

Sales Units	same end as bar code	13 mm (0.5")	On same line and immediately preceding unit size. Indicate the number of bottles/units per shipping container. For multiple sales units, indicate the number of sales units per shipping container and the number of bottles per sales unit using the following format: 4 (6 X 355 ml.).
Unit Size	same end as bar code	13 mm (0.5")	Express in litres (L.) or millilitres (ml.).
Product Type (optional)	same end as bar code	13 mm (0.5")	Generic description of the product type (e.g. white wine, red wine, liqueur etc.).
Product Description required after Jan. 1, 1999	same end as bar code	10.6 mm (0.42")	Describes the product: including brand name. May include vintage year (e.g. World Vineyards Ch. blanc 1992). May be part of preprinted graphics.
Bottle Orientation (<u>only for corked products to be stored corks down</u>)	same end as bar code symbol	76 mm. (3")	An illustration of the orientation of the bottles in the shipping container. The bottle symbol should only be used on corked products and only if they are to be store corks down. The symbol should show the orientation of the bottles in the case.
Shipping container Weight	one end	13 mm (0.5")	Approximate weight, in kg. of the full shipping container (not intended as a shipping weight)

Description of Product on Shipping Container

The intent of this requirement is to allow for easy recognition of the product where scanning is not normally used e.g. the stock area of retail stores.

A human readable description of the retail product must appear on all shipping containers. (Product packed in trays is exempt if the contents of the tray can be readily identified without removing it from the tray.) The brand name must be included if the same product e.g. white rum or Chenin Blanc is offered by multiple suppliers. The vintage year may also be included at the supplier's option.

The description may be printed on the case, applied on a label or incorporated into the preprinted package graphics.

The font used must be at least 30 points 10.6mm. (0.42 inches high).

The description must be located on the same end of the case as the bar code.

When the case contains a value added promotion (free item) or special packaging the description on the case should be changed to allow easy identification of the promotion product or packaging. A label with text may be used in addition to the regular case description.

Structure of the U.P.C. Shipping Container Code (SCC-14)

The Shipping Container Code is a fourteen digit number closely related to the U.P.C. or EAN on the selling unit.

U.P.C.	0 12345 67890 5
SCC-14	1 00 12345 67890 2

EAN-13	93 12345 67890 7
SCC-14	1 93 12345 67890 4

The left most digit of the SCC-14 is a Packaging Indicator. This digit is used to differentiate between containers with different quantities of the same item. In this way, a supplier could offer a case of six or a case of twelve; only the packaging indicator and check digit would change.

The packaging indicator can also be used to differentiate changes in the consumer package, such as a temporary gift box, an on-pack promotion or glass versus plastic packaging. This allows different types of warehouse inventory to be easily identified by both the supplier and the retailer.

The digits, one through eight, can be used as the packaging indicator. Therefore, up to eight different container configurations can be accommodated.³

The digits in positions three through thirteen of the SCC-14 correspond to the first eleven digits of the product's U.P.C. number. For an EAN format number, the digits in positions two through thirteen would correspond to the first twelve digits of the product's EAN number.

The final digit is a check digit but, because it is calculated on the preceding thirteen digits including the packaging indicator, it will be different from the check digit of the U.P.C.

Packaging Indicator "0"

When the middle eleven or twelve digits of the SCC-14 are not the same as those on the retail unit then a packaging indicator of "0" must be used.

U.P.C.	0 12345 6789 <u>0</u> 5
SCC-14	<u>0</u> 00 12345 6789 <u>3</u> 6

³ Packaging Indicator "9" is reserved for non-retail items and should not be used.

It is the practise of some companies to assign SCC-14 numbers that are completely unrelated to the number on the selling unit. The first ten digits of the retail unit U.P.C.-A or the first eleven digits of the EAN-13 should be used whenever possible. The use of a completely unrelated number on the shipping container creates unnecessary complication and has been shown to increase errors in communicating information between buyers and suppliers and should, therefore, be avoided.

Bar Code Format

The bar code may be printed using either the Interleaved 2 of 5 (ITF) or the UCC/EAN-128 format.

The symbol may be printed directly on the carton or applied on a label. If a label is used the glue or adhesive must completely cover the back surface of the label.

The Interleaved 2 of 5 symbol is usually better suited for direct printing on the shipping container. The UCC/EAN-128 version is smaller but requires a higher printing resolution that makes it the preferred choice when printing on labels.

Interleaved 2 of 5 Symbol

The Interleaved 2 of 5 bar code may be preprinted on the shipping container. It may also be printed on the shipping container at the time of filling. It is suitable for direct printing, flexography or ink jet printing.⁴

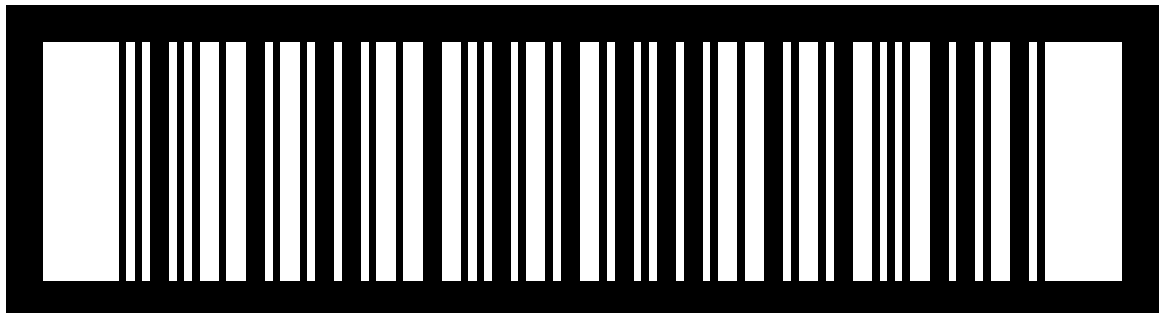

1 0 0 1 2 3 4 5 6 7 8 9 0 2

Shipping Container Code - Interleaved 2 of 5 with bearer bar - approx. 100% nominal size

The human readable characters are printed below the symbol in the Interleaved 2 of 5 format.

The border around the symbol is called a bearer bar. It is designed to ensure even pressure when printing the symbol and also helps to prevent misreads during scanning.

⁴Complete specifications for the symbol are available from the Electronic Commerce Council of Canada or the Uniform Code Council in the publication Application Standard for Shipping Container Codes.

The bearer bars must touch the top and bottom of the vertical bars. There can be no space between the bearer bars and vertical bars.

The thickness of the bearer bar depends on the type of printing process used and the size of the symbol.

Heavier bars are required if the symbol is printed directly on the shipping container using a plate printing process. Narrower bearer bars may be used if the symbol is printed onto a label or is ink jet printed onto the shipping container.

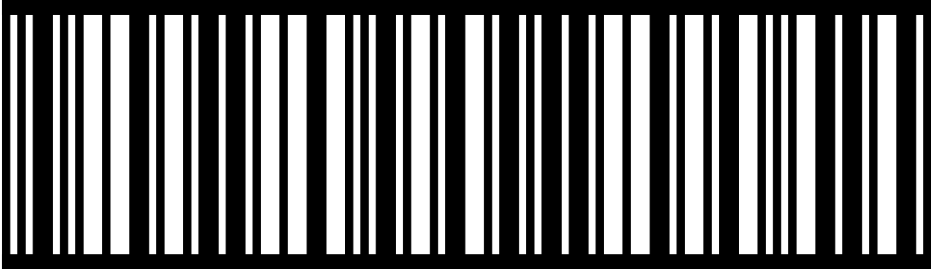

1 0 0 1 2 3 4 5 6 7 8 9 0 2

Vertical bearer bars are only required when the symbol is produced by printing directly on the container using a plate printing process. They are optional when using other printing techniques, such as ink jet printing.

When vertical bearer bars are used, the quiet zones are inside the bearer bars.

A quiet zone is still required at each end of the symbol even when vertical bearer bars are not used.

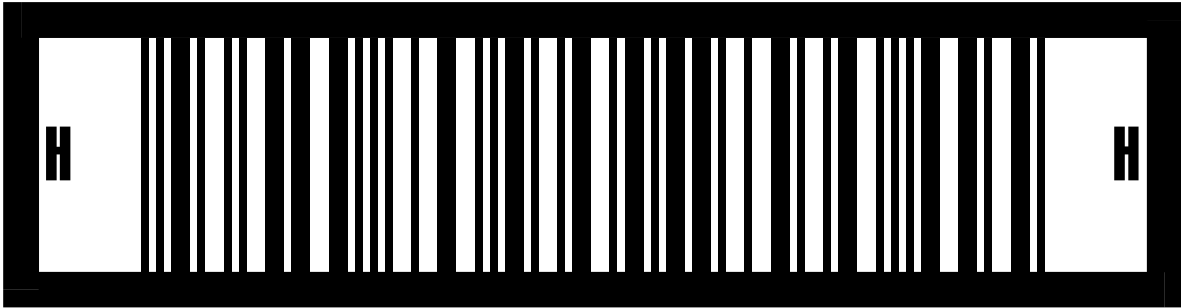

19312345678904

If “H” marks are used as a quality control guide for the printer, they must not intrude into the quiet zone. This will require 3 mm. of additional space at each end of a nominal size symbol.

Depending on the printing process used and the type of material that it is printed on, it may be possible (or necessary) to change the magnification of the symbol. The acceptable magnification range is from 62.5% of the nominal size to 120%. This would produce a symbol that ranges from 92 to 181mm. (3.6 to 7.1 inches) long compared to the nominal or 100% symbol that is 152 mm. (6.00”) long (all measurements include the quiet zone that is required at each end and the vertical bearer bars).

An analysis of SCC-14 symbols on shipping containers has shown that reducing the size of the SCC-14 below 70% dramatically increases the scanning failure rate. Where space or printing equipment restricts the height available, it is better to use a larger magnification even if the space or equipment does not allow for the full bar height. This is explained more fully in the section "Position of the Bar Code Symbol" below.

UCC/EAN-128 Symbol

The UCC/EAN 128 symbology may also be used to produce the Shipping Container Code-14.

(01) 0 00 12345 67890 5

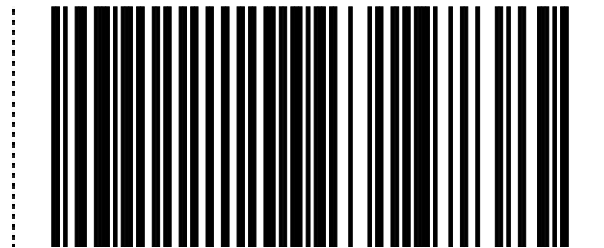

Shipping Container Code in UCC/EAN -128 format

Dotted lines indicate the approximate borders of the quiet zones

UCC/EAN-128 is a family of predefined identification numbers. An application identifier number has been assigned to each member of the family to identify it. When UCC/EAN-128 is used for the SCC-14, the fourteen digits of the shipping container code must be preceded by its application identifier of "(01)".

All sixteen numeric characters will appear in the bar code but the application identifier characters will be discarded by the scanner as soon as the number has been read.

The brackets and spaces only appear in the human readable characters. They are not included in the bar code.

The application identifier is not included when calculating the check digit for the SCC-14.

When using the UCC/EAN-128 bar code the human readable characters should appear above the bars.

In order to allow scanning on a moving conveyor, the minimum symbol size is 71 mm. (2.78") measured from the left edge of the left most bar to the right edge of right most bar. This corresponds to an "X" dimension of 0.508 mm. (0.020" or 20 mils.)⁵.

⁵The X dimension is the width of a narrow bar in a bar code.

Use of U.P.C. or EAN Symbol on Shipping Containers

A U.P.C.-A or EAN-13 symbol should only be used on a shipping container if the shipping container is also a retail selling unit in Canada.

While it has been common in some countries to use a U.P.C. or EAN symbol on shipping containers, the SCC-14 in either the Interleaved 2 of 5 or UCC/EAN-128 format should be used.

The SCC-14 clearly identifies the item as a shipping container and not a retail selling unit.

The Interleaved 2 of 5 is better suited to printing on materials like corrugated cardboard.

U.P.C. and EAN-13 symbols on shipping containers will be accepted as a transitional measure but acceptance of the U.P.C. and EAN-13 on shipping containers may be withdrawn in the future.

If a U.P.C. or EAN-13 is used on a shipping container, it must be at least 160% of nominal size and not larger than 200%.

Position of the Bar Code Symbol

The symbol must appear on one side and one end of the shipping container and always in a horizontal position (never in a ladder style).

Symbol located on the end (shortest panel) of the case

The symbol on the end of the case may be placed at any height on the end panel. It must be located so the nearest vertical bar is at least 32 mm. (1.25") from either vertical edge of the panel.

Note: international standards require that the symbol be placed with the bottom of the vertical bars 32 mm (1.25") (+/- 3 mm or 1/8") from the bottom of the case. This is not required by the CALJ standards but may be required in other markets.

Symbol located on the side (longest panel) of the case

The symbol on the side of the case must be located with the bottom of the vertical bars 32 mm (1.25") (+/- 3 mm or 1/8") from the bottom of the case. The vertical bars must be at least 32 mm. (1.25") from the vertical edge of the panel.



If the vertical bars of the symbol are at least 25 mm. (1.0") high the symbol may be located with bottom of the bars up to 76 mm. (3.0") from the bottom of the case. While placement in the range of 32 to 76 mm. (1.25" to 3.0") is acceptable under the CALJ standards, it may not be acceptable to customers outside Canada.

Symbols on labels

The symbol may be applied on a label. Some rotation of the symbol is acceptable.

The effective height must never be less than 13 mm. (0.5").

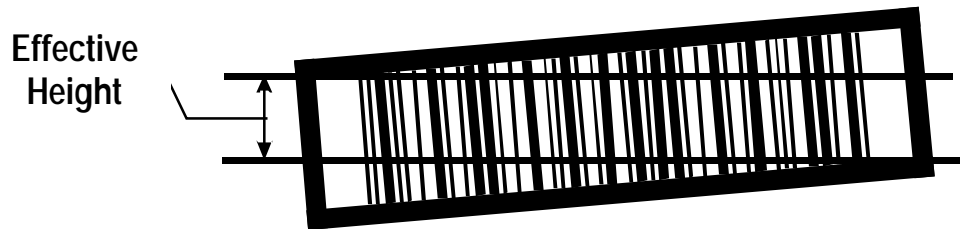

The guidelines for placement of the label described in "Symbol located on the side (longest panel) of the case" above should be interpreted using the effective height of the symbol.

Reduced height symbols

Certain types of printing equipment such as ink jet printers may not be able to print a full height symbol. It may also be difficult to print the full height symbol on some shipping trays.

Reducing the magnification of the symbol to reduce the height may dramatically affect the reliability of scanning.

Under these circumstances, it is preferable to use a higher magnification (wider symbol) even if the bar height does not meet the published specifications.

The effective bar height must never be less than 13 mm. (0.5").

When the bar height is truncated, the symbol must be placed to cover the band from 35 mm. (1.38") to 48 mm. (1.9").

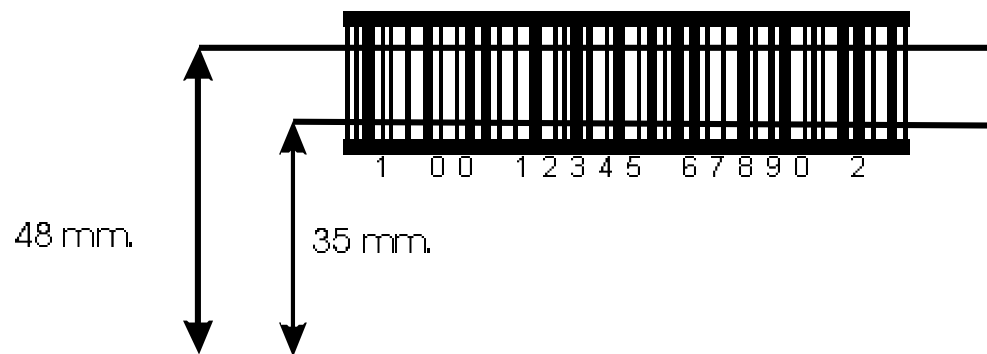

Bar code symbol location on corked products

The symbol on the side of a case of corked product should be placed so that it is near the bottom of the case when the bottles are in the “corks up” position.

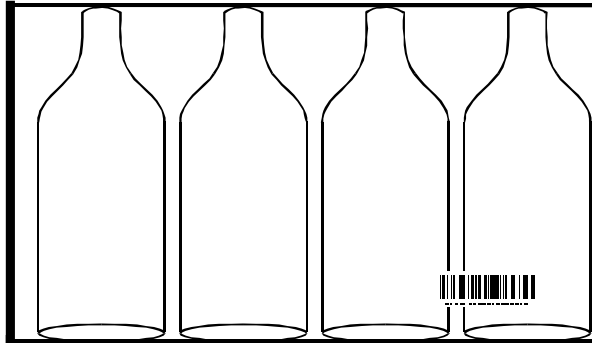

This may result in the symbol being near the top of the case if the product is stored with bottles in the “corks down” position.

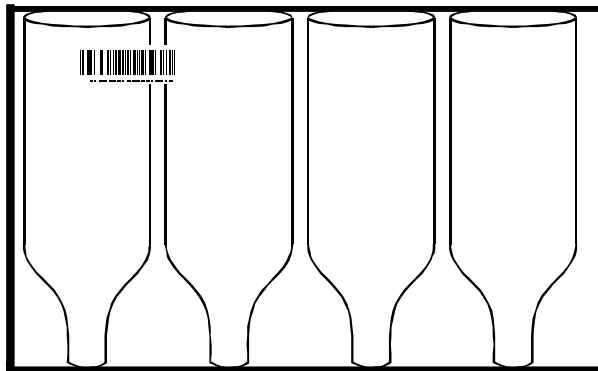

The eye readable markings on the end of the case should be oriented so that they are easily readable in the normal storage position. It is the supplier’s choice as to whether product should be stored with “corks up” or “corks down”. (See also page 12.)

Location of Human Readable Bar Code Number

The standards for Interleaved 2 of 5 and UCC/EAN-128 bar codes have slightly different requirements for human readable information.

The human readable characters should appear above the bar code when using UCC/EAN-128 and below the bar code when using Interleaved 2 of 5 but this requirement will not be strictly enforced.

The following spacing should be used:

Interleaved 2 of 5	0 00 12345 67890 5
UCC/EAN-128	(01) 1 00 12345 67890 2

The human readable characters must be a minimum of 5.0 mm. (0.20”) high. Any sans serif font may be used.

When the Shipping Container is also the Retail Selling Unit

When the shipping container is also a retail selling unit: for example, twelve or twenty four bottles of beer in a closed case, the U.P.C. must be used on the container. The U.P.C. must appear in two locations. Suppliers have the option of placing the U.P.C. on either two adjacent sides or the top and bottom. The SCC-14 is not required but the supplier may put it on the shipping container if they require it for markets outside Canada.

Only one U.P.C. symbol is required when:

1. the shipping container is a selling unit;
2. and the shipping container contains six or fewer bottles or cans;
3. and each of the bottles or cans contains 450ml. or less.

Tray Packed Products

Modified standards have been adopted for tray packed products. These standards apply only to trays of product that pass through a liquor jurisdiction warehouse.

The following markings are required.

1. An SCC-14 bar code on one side and one end.
2. The CSPC number on two ends or on the same end and side as the bar code.

The SCC-14 bar code and CSPC number may appear on the two opposite sides if both of the following conditions apply.

1. The symbol is printed directly on the tray using an ink jet printer.
2. The speed of the conveyor line at the printing location is 25 cases per minute or higher.

The following are required on closed shipping containers but are optional on tray packed products.

1. The number of consumer units.
2. The size (volume) of the units.
3. A human readable description of the product.
4. Approximate shipping container weight.
5. A batch number, lot code, production date, best before date or purchase order number on any one panel.

Standards for Pallets

Unit loads (pallets and slip sheets) must be marked with labels containing the Serial Shipping Container Code (SSCC-18). The actual date will be set by each individual jurisdiction and will not be before June 1, 1999.

Floor loaded product does not require a label.

There is no requirement to label truckloads or inter-modal containers.

Serial Shipping Container Code (SSCC-18)

The SSCC-18 does not identify the product. It is a serial number approach that gives each pallet a unique number.

When the unit load is shipped, relevant information will be transferred from the supplier to the customer by the EDI Advanced Ship Notice (856) or Shipping and Billing Notice (857) transactions. The Shipping and Billing Notice will list the Serial Shipping Container Code and contents of each pallet.

(00) 1 00 12345 55555555 8



Serial Shipping Container Code-18

Dotted lines indicate approximate borders of quiet zone

The SSCC-18 uses a UCC/EAN -128 bar code.⁶

The number is made up as follows.

- (00) - application identifier tells the scanner that the number is a Serial Shipping Container Code
- 1 - packaging type (logistical variant), a one designates a pallet, a two designates a truck load or inter-modal container (a three is typically used on all shipping containers by suppliers in EAN countries)
- 0012345 - the company identification in the EAN format

⁶ UCC/EAN-128 bar codes have some unique properties as compared to standard Code 128. Complete specifications are available from the ECCO or the UCC in the manual Application Standard for Shipping Container Codes

- 555555555 - a serial number used to make each unit unique
- 8 - a check digit. The application identifier (00) is not included in the check digit calculation.

Pallet Label Format

Each pallet will have one bar coded label.

The label must contain a Serial Shipping Container Code (SSCC-18) in the approved UCC/EAN format. The bar code must have an “X” dimension (narrow bar width) of at least 0.762 mm (30 mil. or 0.030”). This will require a label six inches wide.

The symbol bars must be at least 38 mm. (1.5”) high. The human readable digits must be at least 5 mm. (0.2”) high

Suppliers may include other information including other bar codes on the label for their own internal use.

Pallet Label Location

The symbol must be on the face of the load on the right hand side and preferably in the lower right corner.

The label should be applied to a carton on the load. If necessary, the label may obscure some of the data on the case to which it is applied but not the SCC-14.

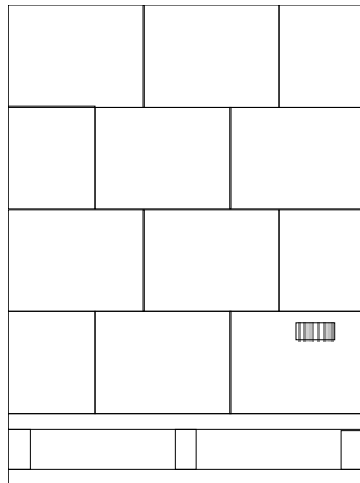

The label must be placed so that right hand edge is 50 to 125 mm. (2-5”) from the right edge of the load.

The preferred vertical location is to place the label near the top of the first carton on the pallet but placement higher on the pallet (up to 1.5 metres or sixty inches from the floor) will be accepted.

If the pallet is shrink-wrapped, the label may be applied before or after the shrink-wrap is applied. The preferred approach is to apply the shrink-wrap after the label has been applied so

that pallet identity is not lost when the shrink-wrap is removed. Tests have established that the bar codes can be scanned through the shrink-wrap. Care is required to ensure that there is not excessive wrinkling in the area of the bar code.

Pallets should be loaded on trucks with the labels facing the doors.

Appendices

Appendix A: U.P.C. Concepts

U.P.C.-A

The most widely used version of the U.P.C. is referred to as Version A.



U.P.C.-A 100%

Dotted lines show
approximate boundaries
of the quiet zones

This symbol has twelve digits that are represented in both bars and in human readable characters.

The first six digits identify the owner/controller of the label and are commonly referred to as the Company or Manufacturer Identification Number⁷. They are assigned by the Uniform Code Council (UCC) in the United States or, in Canada, by the Electronic Commerce Council of Canada (ECCC).

The first of these six digits is referred to as the Number System Character. Originally, all Company Numbers had a first digit of “0” but, all of the numbers available in this series have been assigned and the numbers now being issued begin with a “6” or a “7”.

Following these six digits is a five digit Item Number assigned by the supplier.

The final digit is a check digit that is calculated from the first eleven digits. It is used to verify the accuracy of input during scanning or key entry. (See Appendix “C” for details on the calculation of the check digit.)

Until 1985, the human readable check digit was often omitted although it was in the bars. At this time, it was also common to place the Number System Character half way between the top and bottom on the left side of the bar code. The current guidelines call for all twelve characters to be visible and to be aligned along the bottom of the bar code. The use of any other format is discouraged. All twelve digits must be shown in human readable characters.

U.P.C.-E

A few products have a narrower symbol with eight digits. This is called Version E or a zero suppressed number. It is used when the twelve digit number contains four or more consecutive zeroes.

⁷The Company Identification Number on a product may be controlled by a manufacturer, a marketing company who contracts out its manufacturing, or an agent. Generally, it should indicate the company who owns the brand. In this document, the term supplier is used to represent all three.

The number: 0 12345 00005 8
can be represented in Version E as 0 123455 8.

Version E can only be used with numbers that have a Number System Character of "0".



U.P.C.-E 100%

Dotted lines show approximate borders of the quiet zones

Unless the Company Number ends in one or more zeroes, the only Item Numbers that can be used are "00005" through "00009".

The check digit is calculated based on the twelve digits.

Scanners will automatically recognize and interpret a Version E symbol.

If the Company Number ends in one or more zeroes, additional Item Numbers can be used but special rules apply.⁸ These rules can be found in the Symbol Specification Manual available from the UCC or the ECCC.

EAN Numbers

Following its introduction in North America, a version of the U.P.C. was adopted by a number of countries who formed the European Article Number Association (EAN).

It contains one extra digit at the beginning of the number. (The U.P.C. is effectively a subset of the EAN.) In virtually all other respects, the EAN is identical to the U.P.C. This format is referred to as EAN-13.



⁸All Company Numbers ending in zeroes have been issued. The only way to get one is to buy it from the current owner.

There is also a shorter version called EAN-8.



Unlike the U.P.C.-E this is an eight digit number and does not expand to thirteen digits. EAN-8 numbers are assigned individually to companies by their local EAN International affiliate.

Assignment of U.P.C. Numbers

The U.P.C. number is determined by the supplier. Each supplier will use its own Company Number and combine it with whatever five digit Item Number it wishes to assign.⁹

Symbol Quality

Several technical measures are used to evaluate symbol quality. Complying with the print quality standards is primarily the responsibility of the package designer and the printer. Confirming compliance to the standards, should be a normal check before packaging materials leave the printer.

While the standards are quite complex and require sophisticated testing equipment for actual measurement, the principles are relatively simple.

The scanner must be able to distinguish the dark bars from the lighter background and it must be able to determine the relative width of the bars and spaces.

Information on package design and printing is available in the manual Barcoding for Designers, Printers and Packagers. Technical details of the U.P.C. standards are available in the manual Quality Specification for the U.P.C. Printed Symbol. Both manuals are available from the Electronic Commerce Council of Canada or, in the United States, from the Uniform Code Council.

Package design and the printing process both have a significant impact on the quality of the bar code symbol. The symbol must have good contrast between the light and dark bars and the background material must not have too high a reflectance. Spots or voids in the symbol can cause the scanner to mistake these marks for lines or spaces and prevent the symbol from being read successfully.

⁹Some suppliers have attempted to give the Item Number meaning in their own system by using various digits to indicate the type of product, package type or package format. Unless the company has a very limited number of products, these systems can be difficult to maintain. Over time, as new products are acquired or introduced, the structure usually starts to break down.

It is also critical that the number in the human readable portion be the same as the one in the bars.

Symbol size and the colours of the bars and background also have a significant affect on scanning success.

Symbol Size

The U.P.C. symbol can be produced in a range of sizes. The nominal or 100 % symbol is 25.9 cm. (1.020") high X 37.3 cm. (1.469") wide. This size includes a quiet zone or clear space that is required by the scanner at each end of the symbol.



U.P.C. A 100 %

The symbol can be produced with a magnification range of 80% to 200%.

The printing process used and the type of material upon which the symbol will be printed determine the minimum size that can be reliably scanned. Some processes, like letterpress, can more easily achieve all of the necessary standards and will permit a smaller symbol. Others, such as flexography, require a larger symbol to meet the specifications.

The critical issue is resolution. The sharper the image, the smaller the symbol can be. As the symbol gets smaller, the tolerance in the width of the bars becomes more critical.

The width of the symbol includes a quiet zone to the left and right of the bars. The scanner uses the quiet zone to establish a reflectance reading for the background material. This reading is used to establish the contrast between the light background and the dark bars.

For the nominal size symbol, this quiet zone is 03 mm (0.117") W.

The height of the symbol extends from the bottom of the numbers to the top of the bars. This can usually be confirmed by measuring a symbol.

It is generally possible to print at the minimum 80 % magnification factor on most paper labels because of the high quality of the printing methods and the quality of the label materials used.

Some types of products, such as those where the package graphics are printed directly onto cardboard or screen printed onto bottles, may require a larger symbol.

Reducing the Size of the Symbol

Package designers frequently try to minimize the size of the symbol, either because the space available is limited or, because they consider the symbol to be ugly, and therefore a blemish on their art.

Reducing the size of the symbol increases the risk that it will not scan. Most retailers treat a symbol that does not scan in the same way they would treat an unlabelled product.

Several techniques can be used to reduce the size of the label when space is limited.

1. Use the minimum magnification size possible for the printing process and the type of material being printed upon.
2. Use a Version E (zero suppressed) symbol.
3. A very slight reduction can be gained by judiciously reducing the size of the human readable characters.
4. The final technique is truncation or a shortening of the height of the bars. Truncation is commonly used but is not supported in the U.P.C. standards.

Truncation

Truncation can reduce the scanner's ability to read the symbol.

Most scanners read a symbol by projecting a dot of red light in a sweeping pattern onto the symbol and then recording the light reflected back.¹⁰

To read successfully, the dot must travel from one end of the symbol to the other without running off the top or bottom of the symbol. The shorter the height of the bars, relative to the width of the symbol, the more difficult it will be to scan the symbol. This is particularly true for flat-bed or presentation scanners that are installed at the checkout counter. This type of scanner broadcasts the light in many different directions, in a usually successful effort, to find and read a symbol. Unlike a hand held scanner, the operator does not aim the scanner.

On very small packages, truncation (reducing the height of the bars) may be the only way to fit a U.P.C. symbol onto the product. If truncation is used for aesthetic reasons, product may be rejected and/or compliance charges may be assessed.

If truncation must be used, then it must be used with the minimum practical magnification size to reduce the width of the symbol.

¹⁰The light is often generated by a helium-neon laser that is bounced off a moving mirror. The movement of the mirror causes the light dot to move so quickly that it appears as a solid line to the human eye.

Symbol Colours

The critical issue in choosing colours is to provide the best possible contrast between the light background and the dark bars.

Black bars on a white background will always work well but are not the only choice.

The human eye is not a reliable judge of light and dark in a bar code.

Most scanners use red light. Under this red light, yellow and red tend to be invisible. This makes them good choices for background colours while blue and black are best for the bars.

Printing processes create different colours by layering black, blue, red and yellow inks.

Some colours, like browns, that appear quite dark to the human eye may not scan well because they contain a significant amount of red and yellow.

An experienced package designer and a good printer will be able to identify colour combinations that provide scannability while harmonizing with the overall package design.

Orientation of the Symbol

The orientation of the symbol may be dictated by technical issues, such as the direction of the press during printing.

Except for packages that have the symbol on the bottom, the symbol should be positioned to make it easy to read the human readable characters when the package is picked up with the left hand. This is the normal procedure at the point of sale checkout. This means that the symbol must be oriented so that the human readable characters are towards the bottom or on the left hand side.

Symbol Curvature

When a symbol is placed with the human readable characters at the bottom, the curvature of small diameter packages, such as bottles or cans, may distort the distance between lines for the scanner. For example, the maximum magnification for a symbol on a bottle with a 64 mm. (2.5") diameter is 106 %. Any symbol larger than this may not scan because of the distortion introduced by the curvature.¹¹ This distortion can be eliminated by rotating the symbol 90 degrees so that the bars appear as a ladder (parallel to the bottom) rather than in the normal picket fence style (at right angles to the bottom).

¹¹Detailed information including maximum magnification factors for various diameters is available in the U.P.C. Guidelines Manual available from the Electronic Commerce Council of Canada or, in the United States, from the Uniform Code Council.

Appendix B: Relationship to Existing U.P.C. and CSPC Standards

Every effort has been made to conform to the guidelines of the Electronic Commerce Council of Canada and the Uniform Code Council. There are, however, a few instances where this was considered either unnecessary or not possible.

	U.P.C. Standards	CALJ Standards
Bottles in open carriers	mark bottles with U.P.C. apply different U.P.C. to bottom of carrier	apply U.P.C. to bottles only U.P.C. on the carrier is optional. If used it must be different from the number on the bottles.
Free item on pack	no or defaced symbol on free item assign new U.P.C. to main item	no or defaced symbol on free item use regular U.P.C. on main item ¹²
Shipping Container Code on shipping containers	U.P.C. standards have recently been revised to recommend application of the symbol to two adjacent sides of the shipping container	application to two adjacent sides is required
Shipping Container Code on shipping containers	place symbol with bottom of bars 32 mm from bottom of shipping container	may place symbol with bottom of bars 32 mm to 7.6 mm from bottom of shipping container
Shipping container is also a retail selling unit	U.P.C. may be used on two adjacent sides of shipping container in place of SCC-14	U.P.C. is required and may be placed on two adjacent sides or top and bottom of shipping container

¹² This practice recognizes that most free items are applied after the original product has been produced when a U.P.C. change would be more difficult and expensive. In some cases, the free item is applied to in-store inventory.

Appendix C: Calculation of Check Digits

Check digits are usually automatically calculated for you by the film master supplier or by bar code generating software. The check digit for the eight digit U.P.C. Version E is calculated on the full twelve digit number, including the suppressed zeroes. The check digit for the EAN-8 symbol is calculated on the eight digits.

Position	18	17	16	15	14	13	12	11	10	9	8	7	6	5	4	3	2	1
U.P.C.-A						0	X	X	X	X	X	X	X	X	X	X	X	C
EAN-13						X	X	X	X	X	X	X	X	X	X	X	X	C
SCC-14					PI	X	X	X	X	X	X	X	X	X	X	X	X	C
SSCC-18	X	X	X	X	X	X	X	X	X	X	X	X	X	X	X	X	X	C

PI = Packaging Indicator C = Modulus 10 Check Character 0 = Filler 0 for U.P.C. X = Numbers

The same five step process is used for all numbers.

The following example shows the calculation for the SSCC-18 number 0 0012345 55555555 8

Position	18	17	16	15	14	13	12	11	10	9	8	7	6	5	4	3	2	1
SSCC-18	0	0	0	1	2	3	4	5	5	5	5	5	5	5	5	5	5	8

Step 1: Starting from position 2 add up the value of the even numbered positions.

$$5 + 5 + 5 + 5 + 5 + 4 + 2 + 0 + 0 = 31$$

Note that the application identifiers (00) or (01) that are used with UCC/EAN 128 bar codes are not included in the check digit calculation.

Step 2: Multiply the result of Step 1 by 3.

$$31 \times 3 = 93$$

Step 3: Starting from position 3 add up all the odd numbered positions. Position 1 is not included because it is the check digit.

Position	18	17	16	15	14	13	12	11	10	9	8	7	6	5	4	3	2	1
SSCC-18	0	0	0	1	2	3	4	5	5	5	5	5	5	5	5	5	5	8

$$5 + 5 + 5 + 5 + 5 + 3 + 1 + 0 = 29$$

Step 4: Add the results of Steps 2 and 3.

$$93 + 29 = 122$$

Step 5: The check character is the smallest number which when added to the result of Step 4 gives a number that is a multiple of 10.

$$122 + X = 130 \quad X = 8$$

“8” is the smallest number that when added to 122 results in a multiple of 10. Therefore, the check digit in this example is “8”.

Appendix D: Quality Specifications for Symbols

Symbols should be checked regularly with a verifier test instrument at all stages of production and use.

Symbol quality will be evaluated using the methods and standards set out by UCC/ECCC.

The procedure for testing is described in the UCC/ECCC manual Quality Specification for the U.P.C. Printed Symbol and is based on the ANSI symbol specification test.

The following is provided for information only. For detailed information on the test criteria and procedures, please consult the UCC/ECCC or EAN manuals.

At the time of publication of this document, the standards were:

Symbol Type	Minimum Score (ANSI spec.)		Aperture Size
	Numeric	Alpha	
U.P.C./EAN on selling unit	1.5	C	6 mils
All Interleaved 2 of 5	0.5	D	20 mils
y UCC/EAN-128 or U.P.C./EAN on shipping container	1.5	C	10 mils

These results are based on the use of a verifier using light with a wavelength of 670nm +/- 10.

The numeric scores are based on the average of ten scans taken at different locations on the symbol. For averaging, the following weights are used: A=4, B=3, C=2, D=1 and F=0.

These standards specify the symbol quality at point of use. It is recommended that suppliers achieve a quality level at least one grade higher at the point of production to allow for normal wear and tear during handling.

Several companies offer verification services at a nominal fee (approximately \$30 per symbol). A list of these service providers is available from the ECCC. A number of EAN affiliated organizations also offer verification services to their members.

All symbols must pass each of the following criteria.

	Pass Criteria	Fail
Truncation ¹³	No truncation on retail selling unit	Truncation
Magnification on retail selling unit on shipping container on pallet label	$\geq 80\%$ and $\leq 200\%$ see table Appendix G see table Appendix G	< 80 or $> 200\%$
Edge Determination	Pass	Fail
Decode	Pass	Fail
Quiet Zone	Pass	Fail
Minimum Reflectance	0.5 or less of maximum reflectance	> 0.5
Minimum Edge Contrast	15% or greater	$< 15\%$

In addition to passing each of the previous criteria, all symbols must obtain a passing grade on each of the following criteria.

The passing grade is determined by the type of symbol and whether it is on a retail unit or a shipping container.

The final score for a symbol is based on its lowest score in any category.

The symbol fails if it has an "F" on any category.

	A	B	C	D	F
Symbol Contrast	$\Rightarrow 70\%$	$\Rightarrow 55\%$	$\Rightarrow 40\%$	$\Rightarrow 20\%$	$< 20\%$
Modulation	≤ 0.7	≤ 0.6	≤ 0.5	≤ 0.4	> 0.4
Decodability	$\Rightarrow 0.62$	$\Rightarrow 0.50$	$\Rightarrow 0.37$	$\Rightarrow 0.25$	< 0.25
Defects	≤ 0.15	≤ 0.20	≤ 0.25	≤ 0.30	> 0.30

¹³ Vertical bars less than specified height. Truncation will be accepted on very small products where it can be shown that the space available on the product and the label did not allow for a full height symbol.

Appendix E: Glossary of Terms

Application Identifier	The application identifier is a prefix used with UCC/EAN-128 type bar code symbols. It is a two to four digit number that identifies the type of information contained within the symbol.
Bar Code	A bar code is a series of light and dark bars that represent machine readable (scannable) data. The bar code also includes some clear space on each end that is called a quiet zone.
Bar Code Symbol	The Bar Code Symbol consists of both the bar code and the human readable data.
Bearer Bars	Solid bars placed above or around Interleaved 2 of 5 bar codes to prevent misreads and improve print quality
Check Digit	The check digit is a number calculated from the other digits in a bar code symbol according to a specific mathematical calculation. It is used to confirm the accuracy of the data during scanning or key entry.
Clear Space	see Quiet Zone
Company Number	The six digit portion of the U.P.C. number that uniquely identifies a manufacturer or supplier and produces a unique number for the product when combined with an Item Number.
Consumer Unit	The consumer unit is the physical unit that the customer actually buys. An item may have more than one consumer unit, for example a single unit and a package of six units. For some products, the consumer unit may also be the shipping container.
CSPC	A six digit item number that has been used to identify beverage alcohol products sold in Canada. It will eventually be replaced by the U.P.C.
Direct Print	Any printing process in which the printing equipment makes direct contact with the surface to be printed e.g. wet plate and flexography. Non direct printing methods include ink jet printing.
DUN-14	Distribution Unit Number see SCC-14
EAN-14	See SCC-14
EAN International	EAN International is the International Article Numbering Association, Brussels and is responsible for the administration of U.P.C. standards outside North America.
EDI	Electronic Data Interchange is the direct exchange between computers of business information in standard formats.
ECCC	Electronic Commerce Council of Canada assigns Company Numbers to Canadian based companies and publishes U.P.C. related manuals.
Interleaved 2 of 5 (I2 of 5 or ITF)	Interleaved 2 of 5 is a symbology for bar codes. It is well suited to printing directly on rough surfaces such as corrugated cardboard and, therefore, is commonly used on shipping containers.
Item Number	The five digits of a U.P.C. that is unique to each product for a specific supplier. Produces a unique number for the product when combined with the Company's ID Number.

Manufacturer Number	See Company Number
Nominal Size	The typical (100%) size for a bar code. Larger or smaller sizes may be required/possible depending on the material that the symbol will be printed on and/or the type of printing process used.
Packaging Indicator	A single digit that is used as part of the SCC-14. It is used to identify variations in packaging type or shipping container quantity.
Packaging Type	A single digit within the SSCC-18 that is used to identify the shipping unit as a shipping container, pallet or other unit load.
Quiet Zone	The Quiet Zone is a required part of each symbol. It is the clear space before and after the bars that is used by the scanner to locate the symbol and establish the background level for print contrast.
Serial Shipping Container Code (SSCC-18)	The Serial Shipping Container Code (SSCC-18) is a unique number composed primarily of the Company ID Number and a nine digit serial number. It uniquely identifies a shipping container but contains no information about the product or products inside the container. It is intended for use in an EDI environment where the Shipping and Billing Notice (857) transaction Advanced Shipping Notice (856) transaction provides detailed information on the contents for each uniquely numbered container.
Shipping Container Code (SCC-14)	The Shipping Container Code (SCC-14) is an expanded version of the U.P.C. number and is used as an identifier on shipping containers. Shipping containers with identical contents will have the same SCC-14.
Shipping Container	A shipping container is a transport package. It can range in size from carton to trailer load and can include containers such as cartons, barrels and trays.
Standard Shipping Container	A container of a single product or a fixed configuration of multiple products.
Symbology	A method for encoding data in a pattern of bars. Three symbologies are used in connection with the U.P.C. They are U.P.C., Interleaved 2 of 5 and UCC/EAN-128.
TUN-14	See SCC-14
UCC	The Uniform Code Council is a not for profit, membership organization based in Dayton Ohio and issues Company Numbers to North American companies that have their headquarters outside Canada.
UCC/EAN-128	UCC/EAN-128 is a variation on the Code 128 bar code symbology.
Vintage	A crop year

Appendix F: Summary of Version Changes

This appendix summarizes the changes that have been made in each version of this document since its original distribution (June 12, 1995).

May 10, 1996

1. All references to the term U.P.C. were changed to include periods after each letter. The term U.P.C. without the periods refers to the Uniform Plumbing Code and is a registered trademark of the International Association of Plumbing and Mechanical Officials.
2. The abbreviation for the Electronic Commerce Council of Canada was corrected to ECCC.
3. The eight digit version of the EAN is not a zero suppressed number. Reference to it as a zero suppressed number has been deleted.
4. Changes to the U.P.C. number on the retail selling unit should be coordinated with changes to the SCC-14 on the shipping container.
5. The terms SCC-14 and SSCC-18 have been adopted by UCC and ECCC to describe the 14 digit Shipping Container Code and the 18 digit Serial Shipping Container Code. This version now uses this terminology.
6. A reference was added to clarify that the U.P.C. number can only be used on the shipping container if the shipping container is a retail selling unit. Otherwise, the SCC-14 must be used.
7. When the shipping container is also a retail selling unit, the U.P.C. should appear in two locations on the shipping container rather than the SCC-14. Suppliers have the option of placing the U.P.C. on two adjacent sides or on the top and bottom.
8. A change was made to indicate that vertical bearer bars are required on the SCC-14 when printing Interleaved 2 of 5 directly onto the shipping container material but are optional for other types of printing processes, such as ink jet printing.
9. Four new appendices were added.

Appendix.	Title
C	Calculation of Check Digits
D	Quality Specification for Symbols
E	Glossary of Terms
F	Summary of Version Changes

September 1998

1. All references to the Product Code Council of Canada (ECCC) have been changed to the Electronic Commerce Council of Canada (ECCC) which is now responsible for administration of U.P.C. standards in Canada.
2. The acceptance of EAN and U.P.C. numbers on shipping containers has been documented.
3. As of January 1, 1999 the product description is mandatory.
4. Location of the SCC-14 was revised for symbols with bars less than 25 mm. (1.0) high.
5. The supplier now has the choice of placing the CSPC number on either the two ends of the case or on the same side and end as the bar code.
6. Marking requirements for tray packed products were amended and clarified.
7. Clarification on the location of the SCC-14 for corked products was included.
8. Pallet label standards were defined.
9. Additional information on the standards and procedures for measuring bar code quality using the ANSI methodology have been included in Appendix D.
10. Appendix G was added to provide sample dimensions for all bar codes used.

Appendix G: Bar Code Symbol Dimensions

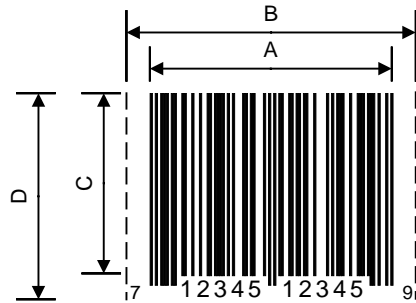

U.P.C.-A

In millimeters				
Magnification	A	B	C	D
80%	25.08	29.83	18.29	20.73
90%	28.22	33.56	20.57	23.32
100%	31.35	37.29	22.86	25.91
120%	37.62	44.75	27.43	31.09
160%	50.16	59.66	36.58	41.45
200%	62.70	74.58	45.72	51.82

In inches				
Magnification	A	B	C	D
80%	0.988	1.175	0.720	0.816
90%	1.112	1.322	0.810	0.918
100%	1.235	1.469	0.900	1.020
120%	1.482	1.763	1.080	1.224
160%	1.976	2.350	1.440	1.632
200%	2.470	2.938	1.800	2.040

U.P.C.-E

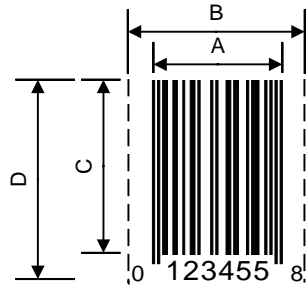

In millimeters				
Magnification	A	B	C	D
80%	13.46	17.69	18.29	20.73
90%	15.15	19.90	20.57	23.32
100%	16.83	22.11	22.86	25.91
120%	20.20	26.53	27.43	31.09
160%	26.93	35.38	36.58	41.45
200%	33.66	44.22	45.72	51.82

In inches				
Magnification	A	B	C	D
80%	0.530	0.697	0.720	0.816
90%	0.597	0.784	0.810	0.918
100%	0.663	0.871	0.900	1.020
120%	0.796	1.045	1.080	1.224
160%	1.061	1.694	1.440	1.632
200%	1.326	1.742	1.800	2.040

EAN-13

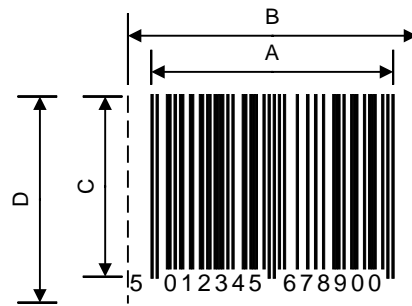

In millimeters				
Magnification	A	B	C	D
80%	25.08	29.83	18.29	20.73
90%	28.22	33.56	20.57	23.32
100%	31.35	37.29	22.86	25.91
120%	37.62	44.75	27.43	31.09
160%	50.16	59.66	36.58	41.45
200%	62.70	74.58	45.72	51.82

EAN-8

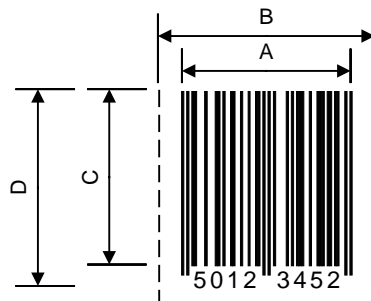

In millimeters				
Magnification	A	B	C	D
80%	17.69	21.38	14.58	17.05
90%	19.90	24.06	16.41	19.18
100%	22.11	26.73	18.23	21.21
120%	26.53	32.08	21.88	25.57
160%	35.38	42.77	29.17	34.10
200%	44.22	53.46	36.46	42.62

SCC-14 using Interleaved 2 of 5 bar code



In inches						
Magnification	X dimension	A	B	C	D	E
70%	0.028	3.374	4.314	0.280	0.190	0.880
80%	0.032	3.856	4.876	0.320	0.190	1.000
90%	0.036	4.338	5.438	0.360	0.190	1.130
100%	0.040	4.820	6.000	0.400	0.190	1.250
110%	0.044	5.302	6.652	0.440	0.190	1.380

In millimeters						
Magnification	X dimension	A	B	C	D	E
70%	0.711	85.728	109.58	7.100	4.826	22.350
80%	0.813	97.998	123.850	8.100	4.826	25.400
90%	0.914	110.278	138.120	9.100	4.826	28.700
100%	1.016	122.348	152.400	10.200	4.826	31.750
110%	1.118	134.618	166.670	11.200	4.826	35.050

The vertical bearer bars are required when printing directly on corrugate using a plate based printing process. When other processes such as ink jet printing or labels are used the vertical bearer bars may be omitted and the width of the horizontal bearer bars may be reduced to twice the X dimension.

The human readable characters must be at least 5.1 mm (0.20").

SCC-14 using UCC/EAN-128 bar code



In inches					
Magnification	X dimension	A	B	C	D
	0.020	2.680	3.180	0.250	1.250
	0.025	3.350	3.850	0.250	1.250
	0.030	4.020	4.620	0.300	1.250

In millimeters					
Magnification	X dimension	A	B	C	D
50.8%	0.508	68.072	80.772	6.350	31.750
63.5%	0.635	85.090	97.790	6.350	31.750
76.2%	0.762	102.108	117.348	7.620	31.750

The human readable characters must be at least 5.1 mm (0.20").

SSCC-18

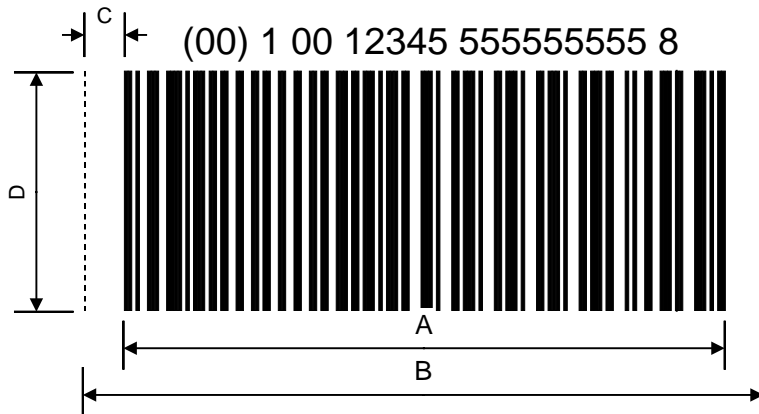

In inches					
Magnification	X dimension	A	B	C	D
@ 76.2%	0.030	4.680	5.280	0.300	1.5

In millimeters					
Magnification	X dimension	A	B	C	D
@ 76.2%	0.762	118.872	134.112	7.620	38.1

The human readable characters must be at least 5.1 mm (0.20").